

WATER MONITOR

Pneumatic Float Switch

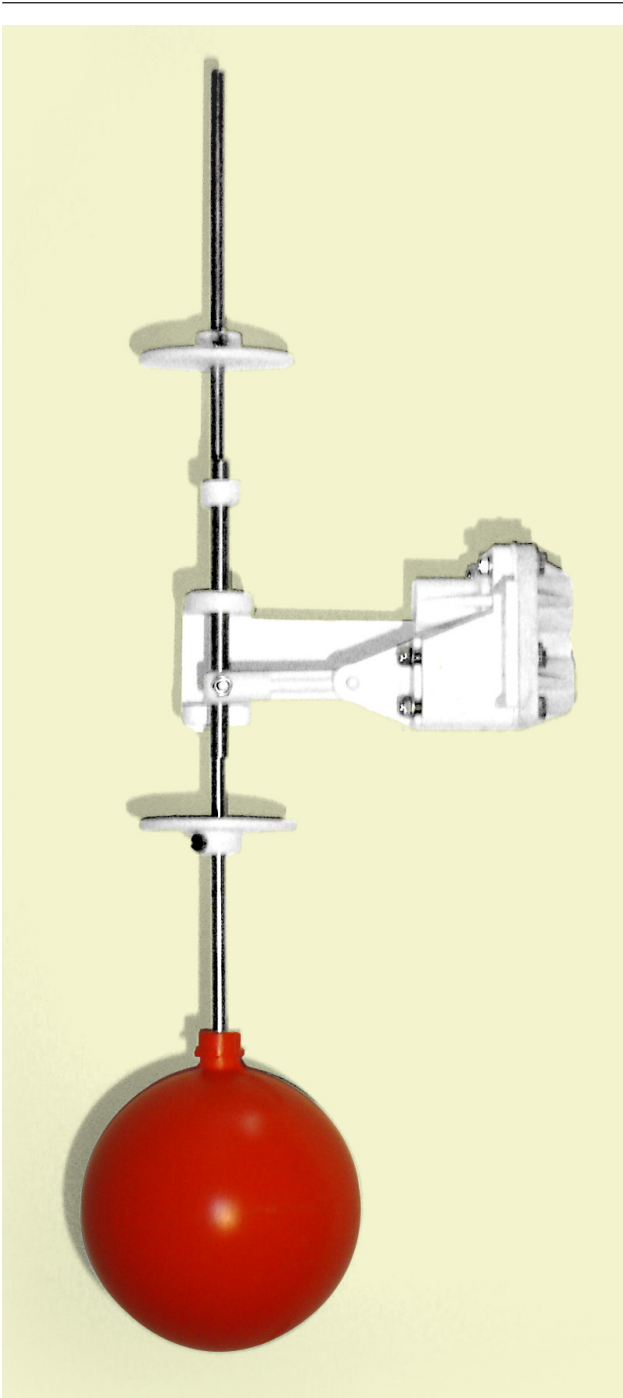

WATER MANAGEMENT

- Water management practices employed in most industries see pumps running 24/7. In practice most pumps only need to be running a small percentage of the time. The Water Monitor float switch was designed to overcome this problem. The float switch will simply turn the pump on when needed, reducing energy consumption and CO² emissions.

Features

- Savings in compressed air and maintenance costs
- Reduced CO² emissions
- Reduced labor cost (reduced pump change outs)
- Less sensitive to dirt and moisture
- Efficient reliable operation
- No lubrication required
- Anti-static rear housing ensures continuity of FRAS hosing
- Plastic and stainless steel construction
- Oil resistant
- Large range of adjustment
- Small long lasting diaphragm

REDUCE ENERGY CONSUMPTION & CO₂ EMISSIONS

Energy Use

Compressed air is often viewed as 'Free Energy', but the production of compressed air can make up a large percentage of total energy usage. The vast majority of compressed air used in mines is for water management.

pump type	CFM max	air consumption per year	KWH	co2 emissions kg	cost
2"Diaphragm	70	36,792,000	96,310	90,000	\$9,631
Air Centrifugal	160	84,096,000	220,146	206,937	\$22,014

note assumptions; 1kwh = 10c = 382 cubic feet @ 700kpa = 0.94kg CO₂

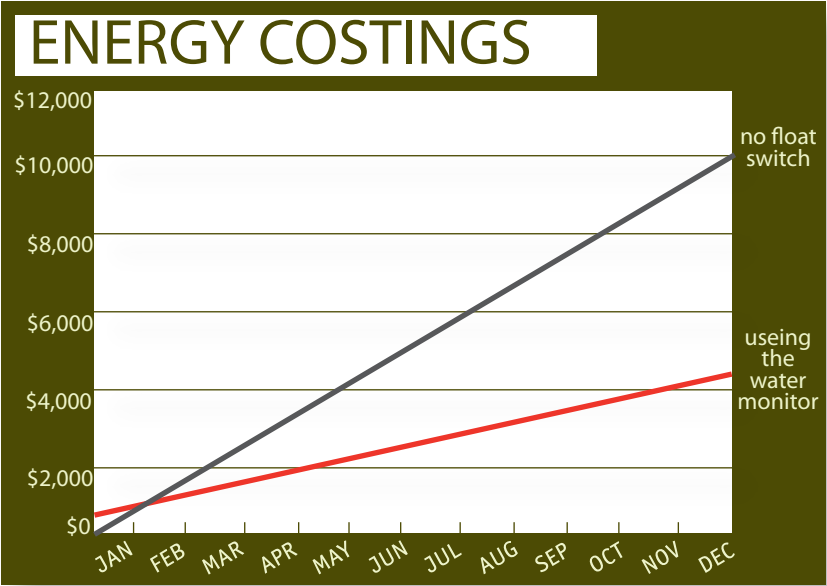

note the above graph shows projected savings over a 12 month period when a water monitor float switch is used, resulting in a 60% reduction in pump running time

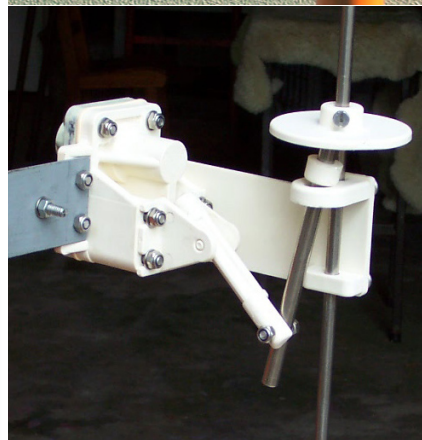

Contact:

www.pumps2000america.com
 562 Alpha Drive
 Pittsburg PA 15238
 phone 412 963 9200
 fax 412 963 9214
 email info@pumps2000america.com